

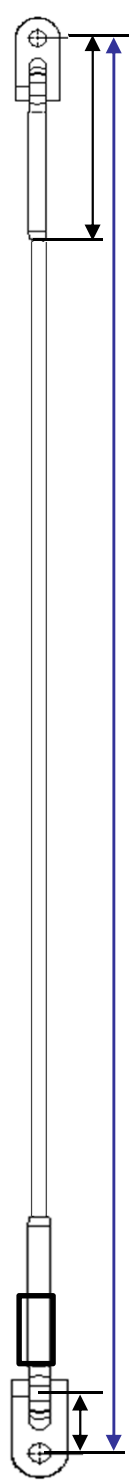

OEM PRODUCT / FICHE CHANTIER
OC4SB CLASSIC & ENR / GENOIS
 FURLING SYSTEM MODEL:
MODELE ENROULEUR: LS180
 FOIL SECTION REF:
REFERENCE PROFIL: SX39

SHIPYARD NAME / NOM CHANTIER:
GRUPE BENETEAU
 CREATED ON/BY: 13/09/19VL indice 03/03/2020DY
 CREE LE/PAR:

**FORESTAY DETAILS
DEFINITION ETAI**



Top terminal Terminaison 214 mm
Head mast pin-to-deck pin forestay length axe cad mât-à-axe cad pont Longueur étai axe à axe 15856 mm
Forestay Ø Ø étai 10 mm
Type CABLE
Manufacturer Fabricant MT
Bottom pin Ø Ø axe bas 16 mm
Toggle width Largeur chape 39 mm
Height toggle Hauteur chape 60 mm
ceil démontable

**FURLING SYSTEM INSTALLATION
MONTAGE ENROULEUR**

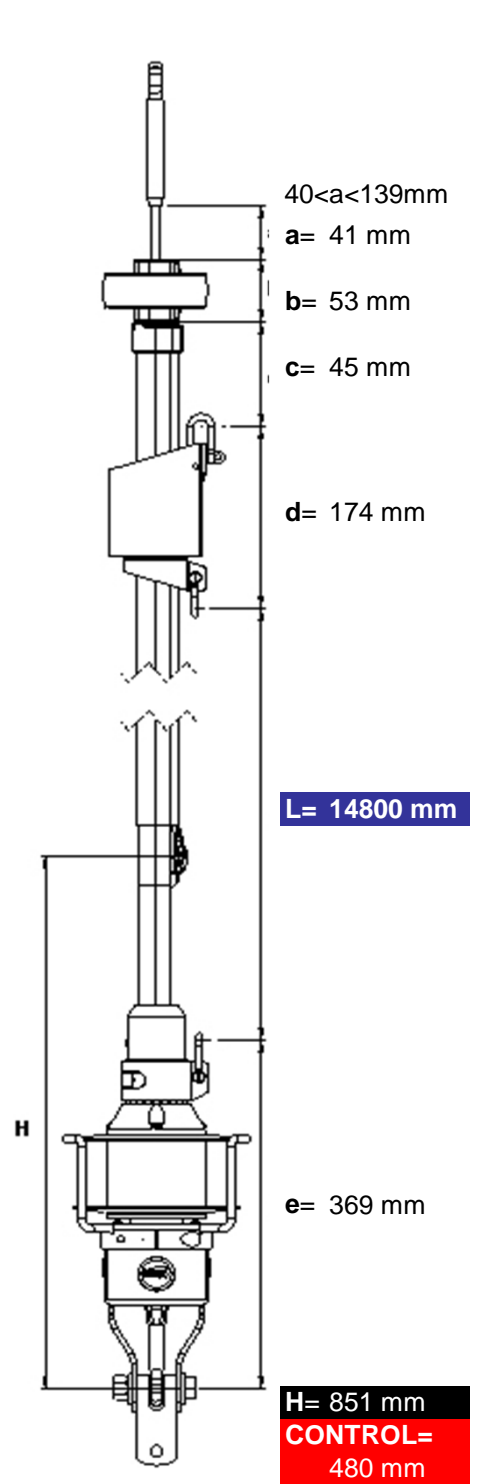

40 < a < 139 mm
 a = 41 mm
 b = 53 mm
 c = 45 mm
 d = 174 mm
 L = 14800 mm
 e = 369 mm
 H = 851 mm
CONTROL = 480 mm

**KIT DETAILS
DETAILS KIT**

FOIL SECTION KIT DETAILS
 Part nber/Code Facnor: **BEN230009800**
 OEM part n/code chant.: **220098**

1 top foil section of / tube haut de **1580 mm**
 6 x 2 m
 1 x 1 m
 1 inner section / tube interne 1465mm
 7 connectors / manchons
 weight parcel/poids colis **18,7 kg**

Foil section and connector dimensions
Dimension profil et manchon

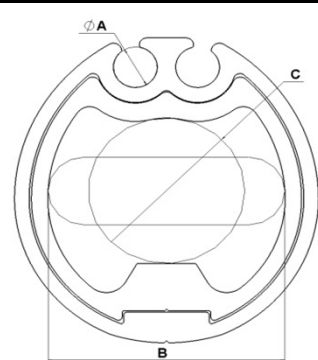

SX39

A=Luff tape Ø Ø rallingue finie ØA= 5 mm
B=max inner width larg interne max B= 32 mm
C=connector inner Ø Ø interne manchon ØC= 21 mm

BOX DETAILS
 Part nber/Code Facnor: **BEN18180600**
 OEM part n/code chant.: **181806**

1 drum/tambour STANDARD	LS180
0 internal turnbuckle fitting/option avale rid.	
1 pin / axe Ø	16 mm
1 link plates of/lattes de	150 mm
toggle width/larg chape	39 mm
12 bushing/paliers	
1 swivel/curseur	
1 halyard deflector wheel/RDD MM	
32 screws/vis	
1 sail feeder/entrée de voile STANDARD	
1 furling line/cordage D8mmx24M white-blue thread/ blanc-filet bleu	
0 stanchion blocks/poulies chandelier	
0 lead fittings/filoirs	
part nber/code	24108240000
weight parcel/poids colis	8 kg

24/10/2019 VL validation BOM MODIFICATIONS DETAILS

Date	By	Details (reasons and actions / raisons et actions)	from order nber/à partir cde n°
03/03/20	DY	MODIF LG ETAI 15756mm	